

GB170WBO

Galaxy

Oval 170cm

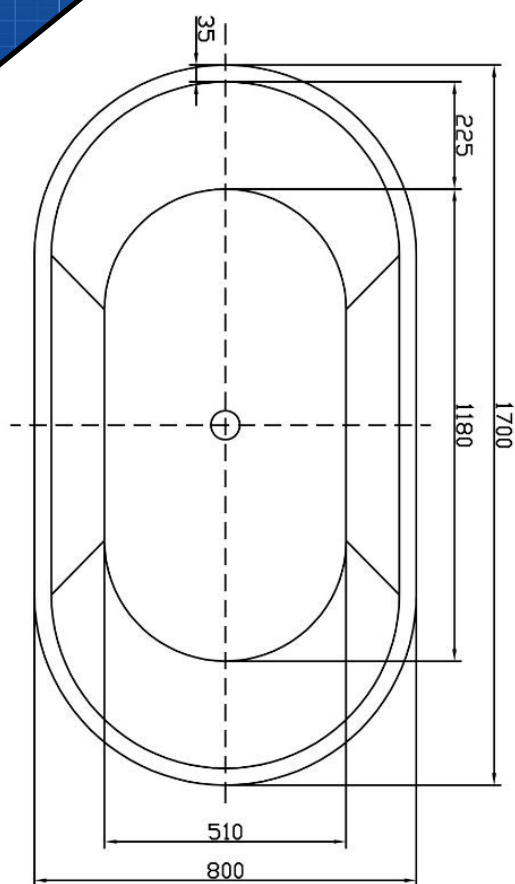

FEATURES & BENEFITS

- Modern styling
- Integrated overflow
- Designed for easy installation
- One piece construction
- Defined Lines
- Pop-Up waste included

SIZE

- 1700mm L x 800mm W x 600mm H

COLOUR

- White internal / black external

MANUFACTURING MATERIALS

- Sanitary grade acrylic & fibreglass
- Stainless steel

GUARANTEE

- All Alpine cabinets come with a genuine 5 Year Warranty which covers materials used and workmanship at the time of manufacture.



Dimensions and set-outs are correct at the time of publication, however the manufacturer/ distributor takes no responsibility for printing errors.

The manufacturer/distributor reserves the right to vary specifications or delete models from their range without prior notification.

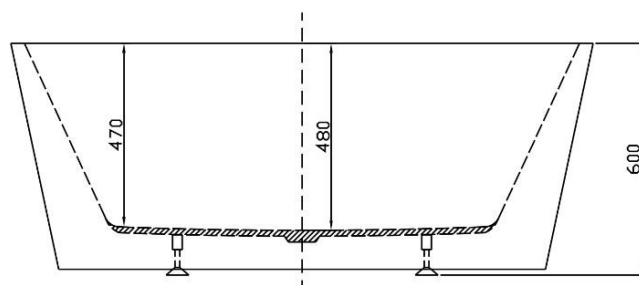

www.alpinekb.com.au